



Multi-Component Gas Analyzer
VA-5000 Series

Sample Gas Conditioning System
VS-5000 Series



Simple, Flexible, and Reliable! Multi-Component Gas Analyzer VA-5000

Flexibility for Various Applications

- Provides wide selection of measurement range; from parts per million (ppm) to percent concentration.
- Capability to simultaneously measure up to four gas components.
* Refer to the specifications table on page 3 for possible combination of modules.
- Automatic internal correction of measurements, such as oxygen (O₂) corrected value. No need for additional external programmable logic controller (PLC).
- Thermostat for optical unit allows use in tougher sample gas conditions.



Measurement

User-Friendly Features

- The 5.7-inch touchscreen LCD with real-time trend graph analysis provides easy recognition of measurement value stabilization.
- Compact size: 430mm(W) x 380mm(D) x 132mm(H)
The three (3) height unit (HU) VA-5000 fits in a 19-inch rack, enabling easy replacement and installation within tight spaces.
- Operates in standard Modbus™ TCP communication with optional analog and digital I/O.
- Continuous data for up to 15 days can be stored via 1GB USB.

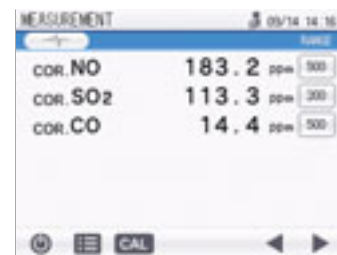

Measurement

Plug & Play Functions

- Modular design allows flexible upgrade of analyzers.
- Modular design enables quick replacement of parameters, which reduces downtime.
- Users need not prepare any time consuming adjustments at site. Just easily plug the connection lines and upload the settings data via USB.



Trend Graph



Series

Other Features

- Auto-calibration function together with the VS-5000 sampling unit, or with external solenoid valves.
- Blowback control function enabling measurement of sample gases with high dust concentration. VA-5000 series can control blowback via digital output with an internal sequencer.
*Please consult HORIBA for further details.
- Multiple analog outputs feature, maximum of eight (8) channels, even for the same parameter.
*Please consult HORIBA for further details.
- Self-diagnosis function enables high/low concentration alarms, calibration error alarm, etc.
- Internal signal data view and logging capabilities for quick system diagnostics, such as "internal temperature control data", "detector voltage signal", etc. Data transfer to users' data logger can be done via Modbus™ TCP.



Concentration Alarm Setting

Auto Calibration Setting



Blowback Setting

Indication of Internal Signals

Sample Gas Conditioning System VS-5000 Series

- Compact, can be easily mounted to a 19-inch rack.
- All sample conditioning components (pumps, coolers, filters, flow controls, NO_x converter, etc.) are integrated into a single case.
- Depending on the application, one (1) unit of VS-5000 may support up to two (2) VA-5000 units.
*Please consult HORIBA for further details.



Application Examples

- The VA-5000 series provides wide range of measurement capabilities for research and development (R&D), for quality control (QC), and/or as continuous emission monitoring system (CEMS).
 - CEMS
 - Emission monitoring of N₂O for sludge waste incinerator
 - Selective catalytic reduction (SCR) research
 - Fuel cell research
 - Green house gases (GHG) research
 - Animal farming's metabolism research
 - Calibration gas quality control
 - Combustion appliance quality control
 - Small boilers' combustion efficiency control
 - Monitoring of biogas, e.g. biogas during fermentation of biodegradable materials
 - Steel production plants' process control, like direct-reduced iron (DRI) manufacture monitoring
 - Water treatment plants' aeration tank's O₂ monitoring
 - Shape memory shirts' production process control
 - Combustion furnace process control for ceramic production (porcelain, sanitary ware, advanced materials, etc.)

Customized combination of modules and sampling units satisfies diverse measurement needs.

Module	Analyzer	NDIR1	NDIR2	NDIR3	CLA	MPA	Galvanic	Zirconia	PMA	Sampling Unit			
		CO·CO ₂ ·CH ₄ ·N ₂ O·NO·SO ₂ ·NH ₃			NO _x		O ₂				VS-5001	VS-5002	VS-5003
1	VA-5001	•								•			
	VA-5002				•							•	
	VA-5003					•					•		
	VA-5004						•			•			
	VA-5005							•		•			
	VA-5006								•	•			
2	VA-5011	•	•							•			
	VA-5012	•			•							•	
	VA-5013	•				•					•		
	VA-5014	•					•			•			
	VA-5015	•						•		•			
	VA-5016	•							•	•			
	VA-5023				•	•							•
	VA-5024				•		•						•
	VA-5025				•			•					•
	VA-5026				•				•				•
3	VA-5111	•	•	•						•			
	VA-5112	•	•		•							•	
	VA-5113	•	•			•					•		
	VA-5114	•	•				•			•			
	VA-5115	•	•					•		•			
	VA-5116	•	•						•	•			
	VA-5123	•			•	•							•
	VA-5124	•			•		•						•
	VA-5125	•			•			•					•
	VA-5126	•			•				•				•
4	VA-5111G	•	•	•			•			•			
	VA-5112G	•	•		•		•					•	

*Please consult HORIBA for further details.

Wide selection for the multiple measurement ranges included in each module

Measurement method	Component	Option range	Standard range		Zero drift		Span drift*1		Repeatability
		High Sensitive Min. range	Min. range	Max. range	Standard range	High Sensitive	Standard range	High Sensitive	
NDIR	CO	0-50 ppm	0-200 ppm	0-100 vol%	±2.0%/week of F.S.	±2.0%/day (CO : 0-50-99 ppm range, CO ₂ : 0-50-99 ppm range, SO ₂ : 0-100-199 ppm range)	±2.0%/week of F.S.	±2.0%/day (CO : 0-50-99 ppm range, CO ₂ : 0-50-99 ppm range, SO ₂ : 0-100-199 ppm range)	±0.5% of F.S.
	CO ₂	0-50 ppm	0-100 ppm	0-100 vol%					
	CH ₄	0-100 ppm	0-200 ppm	0-100 vol%					
	N ₂ O	NA	0-100 ppm	0-5000 ppm					
	NO	NA	0-500 ppm	0-1 vol%					
	SO ₂	0-100 ppm	0-200 ppm	0-10 vol%					
CLA	NO/NO _x	NA	0-20 ppm	0-5000 ppm	±2.0%/week of F.S.				±0.5% of F.S.
MPA	O ₂	NA	0-5 vol%	0-100 vol%	±2.0%/week of F.S.		±2.0%/week of F.S.		±0.5% of F.S.
Galvanic		NA	0-5 vol%	0-25 vol%	±1.0%/day of F.S.		±1.0%/day of F.S.		±0.5% of F.S.
Zirconia		NA	0-5 vol%	0-25 vol%	±1.0%/week of F.S.		±2.0%/week of F.S.		±0.5% of F.S.
PMA		NA	0-5 vol%	0-100 vol%	±2.0%/week of F.S.		±2.0%/week of F.S.		±0.5% of F.S.

Note 1: Select multiple measurement ranges within the above minimum and maximum range table in accordance to the following conditions.

[NDIR] Five (5) ranges; the highest range must be within the maximum limit ratio of 10x the lowest range. Maximum limit of 20x the lowest range is also an available option, which may be limited by the cell length.

[CLA] Eight (8) ranges; the highest range must be within the maximum limit ratio of 100x the lowest range. If the maximum range exceeds 2000ppm, the minimum range should be at least 50ppm or more.

[MPA] Five (5) ranges; the highest range must be within the maximum limit ratio of 10x the lowest range.

[Galvanic] Five (5) ranges; the highest range must be within the maximum limit ratio of 5x the lowest range.

[Zirconia] Five (5) ranges; the highest range must be within the maximum limit ratio of 5x the lowest range.

[PMA] Three (3) ranges; the highest range must be within the maximum limit ratio of 10x the lowest range.

Note 2: Contact HORIBA if you require measurement of special gases or ranges.

*1% of span drift for NDIR is achievable with special adjustment at factory. Please contact the HORIBA team for further details.

Various combinations of sensor modules provide excellent flexibility

The free combination of measurement modules, which utilizes different technologies to measure various gases, makes the VA-5000 series truly applicable to the diverse needs of gas analysis for process control, environmental monitoring, research and development (R&D) testing, etc. The sensors lineup includes: the dual-beam non-dispersive infrared (NDIR) absorption method, which measures nine (9) different gases in wide ranges; the chemiluminescence (CLA) method, which allows measurement of mono-nitrogen oxides (NO_x) in low concentrations; and four (4) types of oxygen (O₂) detectors that users may select from to meet measurement requirements.

SO₂, CO, CO₂, CH₄, N₂O, NO, NH₃

NDIR

Dual-beam Non-Dispersive Infrared Absorption Method

As sample gas flow through the measurement cell, a beam of infrared energy (at a wavelength appropriate for the gas being measured) travels through the sample gas and strikes the infrared (IR) detector. The gas being measured absorbs infrared energy and reduces the energy reaching the IR detector. As a result, the pressure of the gas in the first chamber of the detector is reduced, causing gas to flow from the first chamber to the other. This gas flow passes over the precise temperature sensor before entering the second chamber and reduces the resistance value of the sensor element. Since the resistance value was previously calibrated relative to a specific gas concentration, the measured resistance value can be displayed as a gas concentration reading for the sample gas. HORIBA's Micro Electro Mechanical Systems (MEMS) technology allows the manufacture of IR temperature sensor that is very small yet very sensitive, highly reliable, and vibration-resistant.

*When using the NDIR carbon dioxide (CO₂) analyzer, ensure that the background concentration of CO₂ in the operating environment is stable.
*CO interference for N₂O measurement is eliminated by improved NDIR detector.

NO/NO_x

CLA

Chemiluminescence method

The mono-nitrogen oxides (NO_x) analysis module uses the sensitive chemiluminescence (CLA) method, which permits NO_x measurements for range as low as 0-20 ppm. The chemiluminescence analyzer has virtually zero interference. HORIBA's special technology and experience has effectively eliminated CO₂ quenching and water vapor interference.

O₂

Choose from four analysis methods for the oxygen (O₂) analyzer module.
Select the sensor module based on your specific requirements and sample gas conditions.

MPA

Magnetopneumatic

Highly accurate and stable measurement unaffected by coexisting gases or external vibration.

Zirconia

Zirconia

Stable measurement unaffected by environmental conditions

Galvanic Cell

Galvanic cell

Stable measurement with a compact and lightweight sensor

PMA

Paramagnetic

High accuracy, fast response time, and absolute linearity measurement advantages.

Characteristics of O₂ analyzers

		MPA	Zirconia	Galvanic	PMA
Performance	Stability of design	●	●		●
	Warm-up and start-up performance		●	●	
Sample gas condition	Flammable gas is present	●			
	High-concentration acidic gas is present	●			
	Sample flow rate should be minimized	●			●
Installation environment	Carrier gas is not available		●	●	●
	VS-5000 sampling system is not used		●	●	●
Cost and other factors	Installation environmental is vibrating		●	●	
	Operation costs should be minimized		●		●
	Maintenance should be minimized	●	●		●

*When using the zirconia oxygen (O₂) analyzer and the sample gas contains reducing gases, such as carbon monoxide (CO), total hydrocarbons (THC), and/or hydrogen (H₂), to prevent rapid deterioration of the zirconia sensor, the coexisting oxygen and water vapor concentrations must exceed the total concentration of the reducing gases.
The sample gas must meet this requirement: Reducing gas + H₂ < H₂O + O₂

Types of reducing gas: CO, H₂, and THC
Allowable concentrations: CO < 5000 ppm,
H₂ < 1000ppm, when THC is included, CO + H₂ < H₂O + O₂

Sample computation of reducing gases concentration acceptability

Types of reducing gas: CO H₂ THC

Allowable concentrations: CO <5000 ppm, H₂ <1000 ppm. When THC is included, CO +H₂ <H₂O + O₂

Example 1: $\frac{\text{THC}}{1000\text{ppm}} + \frac{\text{CO}}{2000\text{ppm}} + \frac{\text{H}_2}{1000\text{ppm}} < \frac{\text{H}_2\text{O}}{8000\text{ppm}} + \frac{\text{O}_2}{1000\text{ppm}}$ (acceptable)

Example 2: $\frac{\text{THC}}{5000\text{ppm}} + \frac{\text{CO}}{4000\text{ppm}} + \frac{\text{H}_2}{1000\text{ppm}} < \frac{\text{H}_2\text{O}}{8000\text{ppm}} + \frac{\text{O}_2}{1000\text{ppm}}$ (unacceptable)

Specifications

VA-5000 Analyzer

Measurement principle		NDIR	CLA	Magnetopneumatic	Galvanic cell	Zirconia	Paramagnetic
Performance	Linearity	Standard	±1.0% F.S.				
		Option	±2.0% F.S.(range ratio 1:20)				
	Response time*1	30 sec (T ₉₀), 40 sec (Td+T ₉₀); single component					
Flow rate	Standard	60 min (90 min for SO ₂)	60 min	60 min	40 min	20 min	120 min
	Option	0.5L/min	0.3L/min	0.5L/min	0.5L/min	0.5L/min	0.5L/min
Communication		1.0L/min*2					
Data storage		Ethernet (Modbus™/TCP)					
Input/Output (option)		USB memory					
Analog	Input	Maximum 4ch, 0-16 mA / 4-20 mA / 0-20 mA or 0-1 V isolated					
	Output	Maximum 8ch, 0-16 mA / 4-20 mA / 0-20 mA or 0-1 V isolated, Current output: load resistance < 750Ω, Voltage output: input impedance > 100k Ω					
Digital	Input	Maximum 16ch, isolated, Open voltage: 24 V, Short-circuit current 10mA Maximum load resistance < 50 Ω, Minimum pulse width: 0.5 sec					
	Output	Maximum 16ch isolated, Maximum voltage DC 30 V, Maximum current 1A Minimum voltage DC 0.1 V, Minimum current 0.1 A					
Sample condition		Ambient temperature, dust free, H ₂ O less than 5°C saturation, Pressure 0 to 490 Pa					
Gas connections		Inlet and outlet - 6 mm/4 mm PTFE: a single gas inlet is provided standard; the gas flows sequentially from one module to the next; as an option separate gas inlets can be provided for each module.					
Gas tubing		PTFE; stainless steel optional					
Joint		Sample Inlet: Rc 1/8(φ6/φ4mm PTFE joint), Exhaust: φ6/φ4mm PTFE joint Air Inlet: Rc 1/8(φ6/φ4mm PTFE joint); installed CLA. CLA: Exhaust: φ6/φ4mm PTFE joint; installed CLA, MPA Outlet: φ6/φ4mm PTFE joint; installed MPA, Zero gas Outlet: φ6/φ4mm PTFE joint; installed MPA					
Installation		Temperature 0-45°C, Humidity 90% (No condensation), Altitude Max 3000m (combination with only NDIR), (combination with Zirconia, Galvani, MPA, and CLA: max 2000m), No fluctuation of backpressure					
Protection degree		Equivalent to IP20					
Power		100-240 V AC (±10%, maximum voltage 250 VAC), 50/60 Hz (±1.0%), Consumption: 100 to 350 VA					
Display		5.7-inch touch screen					
Case		19-inch panel mount					
Exterior dimensions		Analyzer: 430 (W) x 380 (D) x 132 (H) mm / Approx. 17 (W) x 15 (D) x 5.2 (H) in Deozone unit for CLA: 111 (W) x 95 (D) x 100 (H) mm / Approx. 4.4 (W) x 3.7 (D) x 3.9 (H) in (protrusions excluded)					
Mass		7 -18 kg / Approx. 15 - 40lb					

*1 Flow rate: 0.5L/min, Faster response time (T₉₀) such as 7 sec is achievable as special option

*2 Available when all components are NDIR and PMA

VS-5000 Sampling Unit

Model	VS-5001	VS-5002	VS-5003	VS-5004
Applicable principles	NDIR, Zirconia, Galvanic cell, MPA, PMA	NDIR, Zirconia, Galvanic cell, MPA, PMA	NDIR, Zirconia, Galvanic cell, MPA, CLA, PMA	NDIR, Zirconia, Galvanic cell, MPA, CLA, PMA
Form	19 inch panel mount			
Sampling method	5°C dry sampling			
Materials	SUS, PP, PVC, PVDF, PTFE, FKM, CR, Glass			
Flow rate	0.5 L/min x 2 systems*1		1.5~5.0 L/min	
Sample supply	0.3L/min x 1 system			
Power	100~240 V AC (±10%, maximum voltage 250V AC), 50/60 Hz (±1%)			
Power consumption	150 VA		200 VA	
Joint	Sample inlet: φ8/φ6 mm PTFE joint, Sample outlet: φ6/φ4 mm PTFE joint Air outlet: φ6/φ4 mm PTFE joint, MPA inlet: φ6/φ4 mm PTFE joint Regulator: φ6/φ4 mm PTFE joint, Calibration inlet: RC1/8(φ6/φ4mm PTFE joint) Bypass outlet/Exhaust/Drain outlet: φ8mm hose end			
Sample gas	Ambient temperature, Dust: less than 0.1mg/m ³ , H ₂ O: less than 60°C saturation with drain pot (Approx. 25% H ₂ O), Pressure: ±980 Pa, SO ₂ : less than 50ppm, NO ₂ : less than 6ppm*2, (Corrosive gas, flammable gas and explosive gas are not included)			
Dimension	430 (W) x 550 (D) x 221 (H) mm / Approx. 17 (W) x 22 (D) x 8.7 (H) in (protrusions excluded)			
Mass	14kg / 31lb	16kg / 35lb	19kg / 42lb	20kg / 44lb

*1 Environmental temperature needs to be less than 35°C. If it's over 35°C, please consult HORIBA.

*2 When the sample gas includes more than 6ppm NO₂, it needs to use optional NO_x converter.

Dimensional Outlines

Rubber feet, deozone unit and mounting brackets (e.g. slide rails, and rack mounting plates) are optional. Unit: mm(in)

VA-5000
(Analyzer)

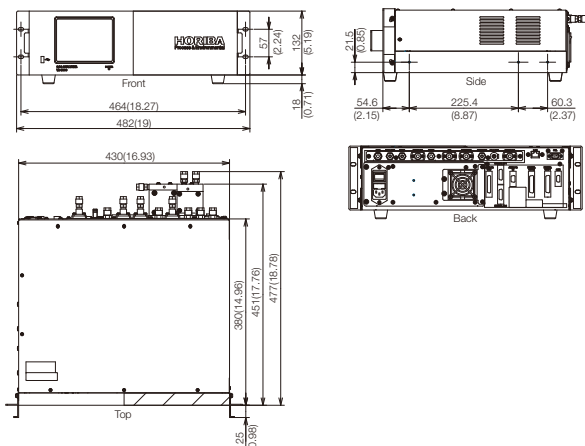

VS-5000
(Sampling Unit)

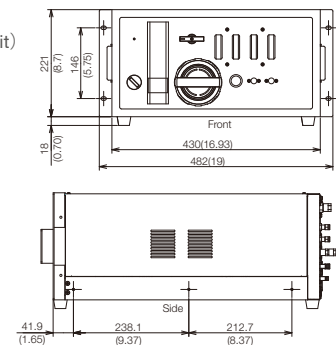

Flow sheet

VA-5111+VS-5001

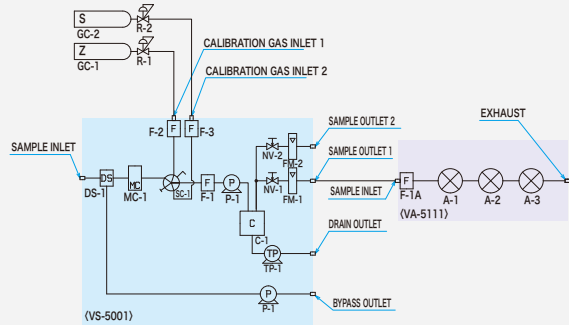

VA-5113+VS-5002

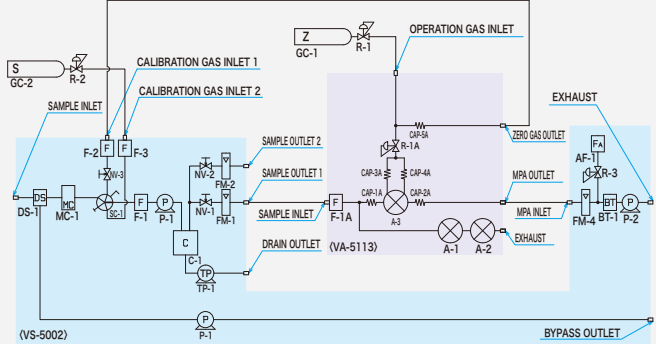

VA-5112+VS-5003

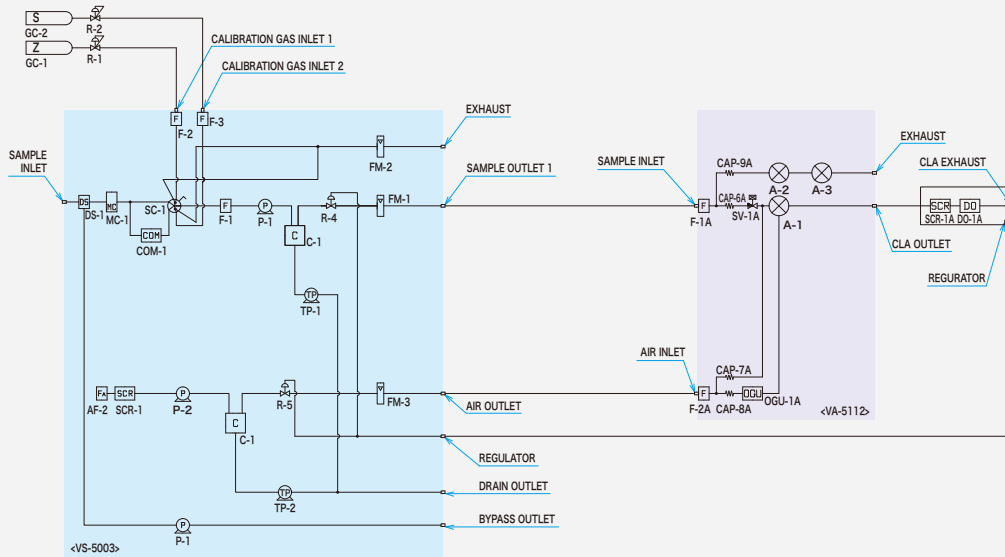

VA-5123+VS-5004

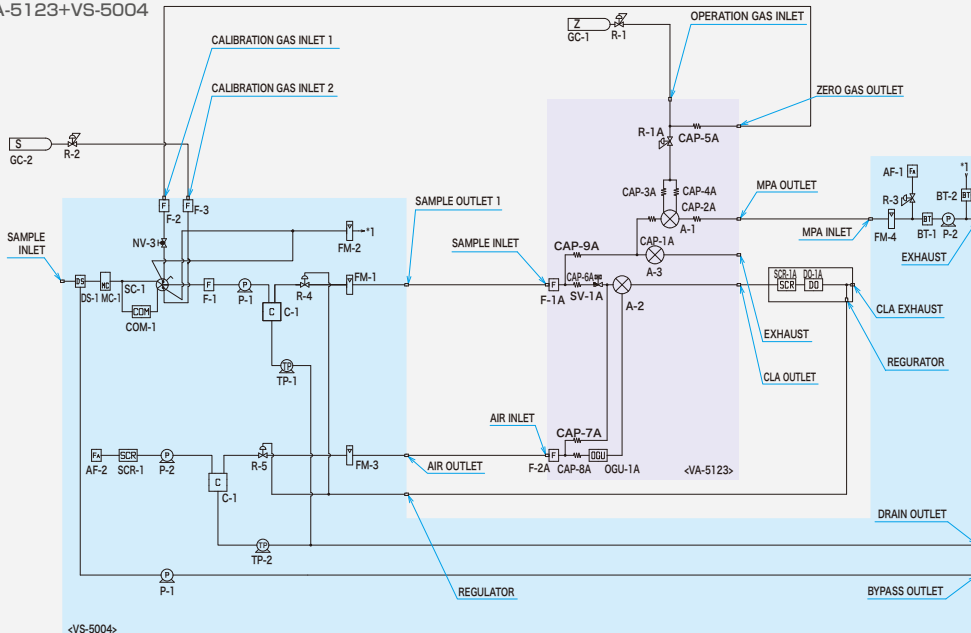

Legend

- A** : Analyzer Unit
- AF** : Air Filter
- BT** : Buffer Tank
- C** : Thermo-electric Dehumidifier
- CAP** : Capillary
- COM** : Converter
- DO** : Deozone
- DS** : Drain Separator
- F** : Filter
- FM** : Flowmeter
- GC** : Gas Cylinder
- MC** : Mist Catcher
- NV** : Needle Valve
- OGU** : Ozonizer
- P** : Pump
- R** : Pressure Regulator
- SC** : Selector Valve
- SCR** : Scrubber
- SV** : Solenoid Valve
- TP** : Tubing Pump

Combined with complimentary HORIBA products, VA/VS-5000 series offers wide range of solutions and applications to various fields and industries.

With consistent expertise in gas analysis, HORIBA provides analyzers for wide array of gases. The combination of VA/VS-5000 series with complimentary HORIBA analyzers provides tailor-made system solutions, which answers the diverse needs of different customers.



Portable Gas Analyzer
PG-300 Series

Capable of measuring five (5) different gas components using a single lightweight, portable, and robust unit. Used for emission monitoring, R&D (fuel cell), stack cross-checking, etc.

NOx SO₂ CO CO₂ O₂ CH₄



Air Quality Analyzer
AP-370 Series

Monitoring of ambient air pollutants: harmful oxides and particulate. Used for ambient air, clean room, indoor air, and trace gas monitoring.

Fits in a standard 19-inch rack

O₃ SO₂ NOx CO CO₂ NH₃ H₂S THC NMHC CH₄ SPM PM_{2.5} PM₁₀ PM₁ PM₄ TSP



Stack Gas Analyzer
GI-700 Series

Designed for continuous measurement of up to six (6) combustion gases simultaneously. The integral sample conditioning system ensures accurate measurement.

Fits in a standard 19-inch rack

NOx CO₂ CO SO₂ NH₃ O₂



The HORIBA Group adopts IMS (Integrated Management System) which integrates Quality Management System ISO9001, Environmental Management System ISO14001, and Occupational Health and Safety Management System OHSAS18001. We have now integrated Business Continuity Management System ISO22301 in order to provide our products and services in a stable manner, even in emergencies.



Please read the operation manual before using this product to assure safe and proper handling of the product.

- The specifications, appearance or other aspects of products in this catalog are subject to change without notice.
- Please contact us with enquiries concerning further details on the products in this catalog.
- The color of the actual products may differ from the color pictured in this catalog due to printing limitations.
- It is strictly forbidden to copy the content of this catalog in part or in full.
- The screen displays shown on products in this catalog have been inserted into the photographs through compositing.
- All brand names, product names and service names in this catalog are trademarks or registered trademarks of their respective companies.

<http://www.horiba.com> e-mail: info@horiba.co.jp

HORIBA, Ltd. Japan

Head Office
2 Miyahonogashi, Kisshoin, Minami-ku, Kyoto, Japan
Phone: 81 (75) 313-8121 Fax: 81 (75) 321-5725

HORIBA (China) Trading Co., Ltd. China

Unit D, 1F, Building A, Synnex International Park, 1068 West Tianshan Road, Shanghai, 200335, China
Phone: 86 (21) 6289-6060 Fax: 86 (21) 6289-5553
Beijing Branch
12F, Metropolis Tower, No.2, Haidian Dong 3 Street, Beijing, 100080, China
Phone: 86 (10) 8567-9966 Fax: 86 (10) 8567-9066

HORIBA KOREA Ltd. Korea

Seoul Branch
10, Dogok-Ro, 6-Gil, Gangnam-Gu, Seoul-Si, 06259, Korea
Phone: 82 (2) 753-7911 Fax: 82 (2) 756-4972

HORIBA Instruments (Singapore) Pte Ltd. Singapore

3 Changi Business Park Vista #01-01 Akzonobel House, Singapore 486051
Phone: 65 (6) 745-8300 Fax: 65 (6) 745-8155

HORIBA Vietnam Co., Ltd. Vietnam

Unit 6, 10 Floor, CMC Tower, Duy Tan Street, Dich Vong Hau Ward, Cau Giay District, Hanoi, Vietnam
Phone: 84 (24) 3795-8552 Fax: 84 (24) 3795-8553

HORIBA (Thailand) Limited Thailand

East Office
850 / 7 Soi Lat Krabang 30 / 5, Lat Krabang Road, Lat Krabang, Bangkok 10520, Thailand
Phone: 66 (0) 2734 4434 Fax: 66 (0) 2734 4438

PT HORIBA Indonesia Indonesia

Jl. Jalur Sutera Blok 20A, No.16-17, Kel. Kunciran, Kec. Pinang Tangerang-15144, Indonesia
Phone: 62 (21) 3044-8525 Fax: 62 (21) 3044-8521

HORIBA India Private Limited India

246, Okhla Industrial Estate, Phase 3 New Delhi-110020, India
Phone: 91 (11) 4646-5000 Fax: 91 (11) 4646-5020
Technical Center
D-255, Chakan MIDC Phase-II, Bhamboli Village, Pune-410501, India
Phone: 91 (21) 3567-6000
Bangalore Office
No.55, 12th Main, Behind BDA Complex, 6th sector, HSR Layout, Bangalore South, Bangalore-560102, India
Phone: 91 (80) 4127-3637

HORIBA Instruments Incorporated USA

9755 Research Drive, Irvine, CA 92618, U.S.A.
Phone: 1 (949) 250-4811 Fax: 1 (949) 250-0924
Houston Office
5390 Bay Oaks Drive, Pasadena, TX 77505
Phone: 1 (281) 482-4334 Fax: 1 (281) 674-6058

HORIBA Instruments Brazil, Ltda. Brazil

Rua:Presbitero Plinio Alves de Souza, 645, Loteamento Polo Multivias Barirro Medeiros-Jundiai Sao Paulo CEP 13.212-181 Brazil
Phone: 55 (11) 2923-5400 Fax: 55 (11) 2923-5490

HORIBA FRANCE SAS France

Les Ulis Office
12. Av des Tropiques Hightec Sud, F-91955 Les Ulis, France
Phone: 33 (1) 69-29-96-23 Fax: 33 (1) 69-29-95-77

HORIBA UK Limited UK

Northampton Office
Kyoto Close Moulton Park, Northampton NN3 6FL, UK
Phone: 44 (1604) 542-500 Fax: 44 (1604) 542-699

HORIBA Europe GmbH Germany

Hans-Mess-Str.6 D-61440 Oberursel Germany
Phone: 49 (6172) 1396-0 Fax: 49 (6172) 1373-85
Leichlingen Office
Julius-kronenberg Str.9 D-42799 Leichlingen Germany
Phone: 49 (2175) 8978-0 Fax: 49 (2175) 8978-50

HORIBA Czech Czech

Prague Office
Prumyslova 1306 / 7, CZ-10200, Praha 10, Czech Republic
Phone: 420 (2) 460-392-65

HORIBA (Austria) GmbH Austria

Kaplanstrasse 5 A-3430 Tulln, Austria
Phone: 43 (2272) 65225 Fax: 43 (2272) 65230

HORIBA (Austria) GmbH Romania

Romania Branch
B-dul.Republicii, nr. 164, Etaj Parter, Birourile nr. 3 si 4 Pitestijudetul Arges110177 Romania
Phone: 40 (348) 807117 Fax: 40 (348) 807118